

LoRaWAN® LUMINAIRE CONTROLLER IP54 UL2002



LoRaWAN® Luminaire Controller is a remote controlling device for LED and HID luminaries using 0...10V analog or DALI control signal.

Control commands from/to dedicated application are to be sent/received using LoRaWAN® network.

OVERVIEW

Universal

Supports LED and HID luminaires.

APPLICATIONS

Luminaires control

Supports customisable dimming profiles

Array control

Allows to control an array of 64 luminaires over the DALI interface

Power monitoring

Monitor used power and luminaire burn time

FEATURES

- DALI interface
- Relay control
- Luminaire intensity control
- IP54
- Surge protection
- Power metering

SPECIFICATIONS

| | |
|------------------------|-------------------------|
| Length: | 134.0 mm |
| Width: | 54.0 mm |
| Depth: | 33.0 mm |
| Weight: | ca 99 g |
| Operating temperature: | -30°C ... +60°C |
| Power consumption: | 230V -15% .. +10% <1V A |
| Communication range: | up to 15 km* LoRaWAN® |
| Tx power: | up to +20 dBm |
| Rx Sensitivity: | -140 dBm |
| MAC Layer: | LoRaWAN® |
| Physical Layer: | LoRa® |
| Body material: | ABS |
| IP Rating: | IP54 |
| Communication: | LoRaWAN® |

* Communication range is dependent on the location of the sensor and nearest base station.

INTERFACE SPECIFICATIONS

| | |
|---|-----------------------------|
| Relay max current: | 6A |
| Surge protection: | IEC 61000-4-5 Class 4 (4kV) |
| Intensity control output voltage: | 0V .. 10V |
| DALI Interface max number of slaves on (int. power supply): | 32 |

DIMENSIONS / PACKAGING

Dimensions

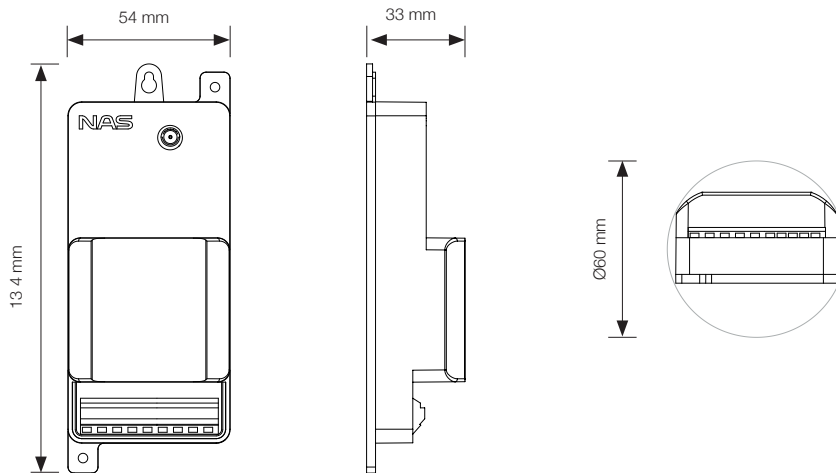

ACCESSORIES

PORT LIST

| fPort | Function | Transmission | Page |
|-------|---------------|--------------|------|
| 24 | Status | ↑↑ | 6 |
| 25 | Usage | ↑↑ | 10 |
| 50 | Configuration | ↑↓ | 13 |
| 51 | Update mode | ↓↓ | 26 |
| 52 | Multicast | ↓↓ | 27 |
| 60 | Command | ↑↓ | 29 |
| 99 | Boot/Debug | ↑↑ | 38 |

For firmware version >= 0.6.29

fPort 24 Status Message

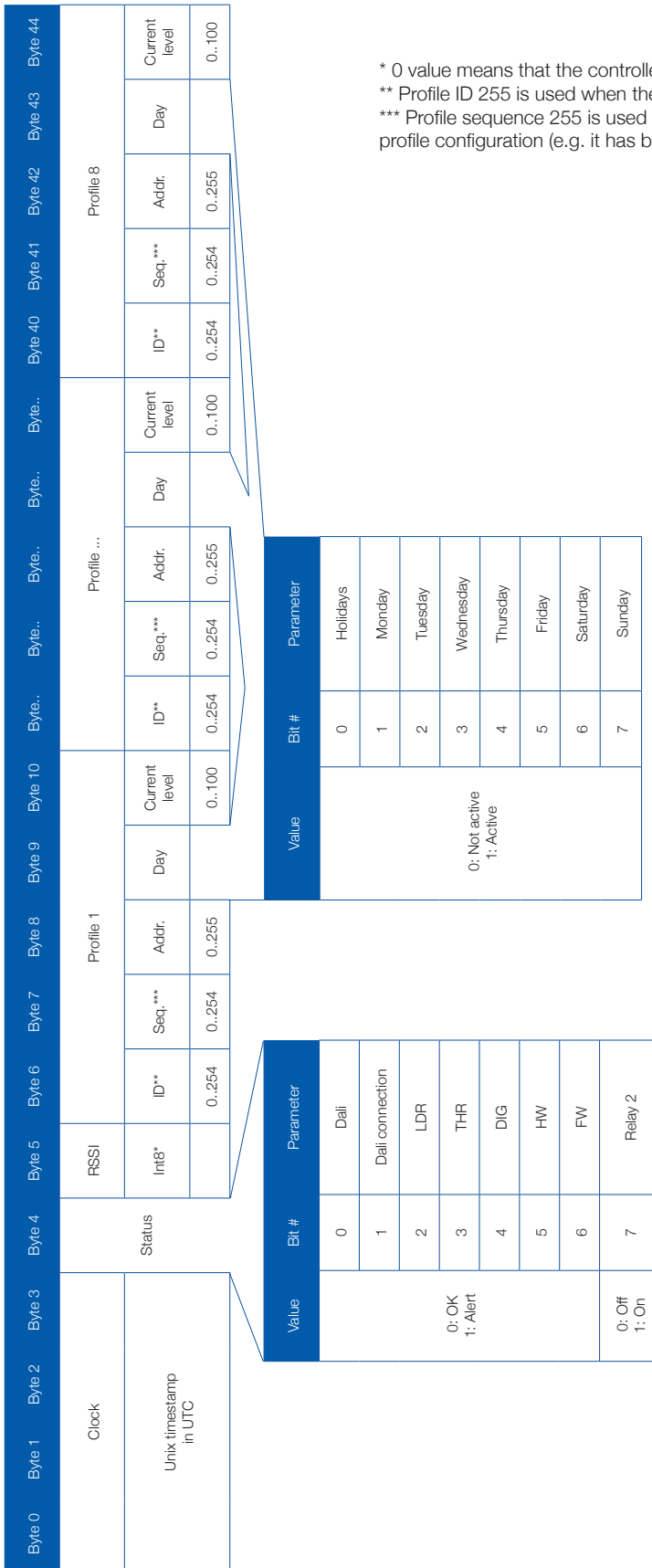

* 0 value means that the controller has not received any packages
 ** Profile ID 255 is used when there is no active profile and the controller is manually controlled.
 *** Profile sequence 255 is used when the current actual light level is not according to the profile configuration (e.g. it has been manually overwritten).

Message sample

Message in base64

```
KOKbWQGOBBb+HjICKv7hMg==
```

Message decoded to HEX

```
28E29B59018E0416FE1E32022AFEE132
```

Device clock `28E29B59` HEX message flip for MSB

```
599BE228
```

HEX message converted to decimal (epoch)

```
1503388200 (seconds)
```

Epoch time converted to date

```
22 August 2017 07:50:00 (UTC)
```

Status HEX message

```
01
```

Status HEX message converted to binary

```
0000 0001
```

Binary converted to statuses (LSB)

```
1 : DALI error - alert
0 : DALI Connection error - ok
0 : LDR error - ok
0 : THR error - ok
0 : DIG error - ok
0 : HW error - ok
0 : FW error - ok
0 : Relay 2 - off
```

Sensor RSSI HEX message

```
8E
```

HEX message converted to signed decimal

```
-114 (dBm)
```

Profile 1 HEX message

0416FE1E32

Profile ID in HEX

04

Profile ID converted to decimal

4

Profile sequence in HEX

16

Profile sequence converted to decimal

22

Profile address in HEX

FE

Profile HEX address converted to DALI address

Broadcast

Profile day setting in HEX

1E

Profile current light dim level converted to binary

00011110

Binary converted to statuses (LSB)

```
0 : Holidays - not active
1 : Monday - active
1 : Tuesday - active
1 : Wednesday - active
1 : Thursday - active
0 : Friday - not active
0 : Saturday - not active
0 : Sunday - not active
```

Profile current light dim level in HEX

32

Profile current light dim level converted to decimal

50%

Profile 2 HEX message

022AFEE132

Profile ID in HEX

02

Profile ID converted to decimal

2

Profile sequence in HEX

2A

Profile sequence converted to decimal

42

Profile address in HEX

FE

Profile HEX address converted to DALI address

Broadcast

Profile day setting in HEX

E1

Profile current light dim level converted to binary

11100001

Binary converted to statuses (LSB)

```
1 : Holidays - active
0 : Monday - not active
0 : Tuesday - not active
0 : Wednesday - not active
0 : Thursday - not active
1 : Friday - active
1 : Saturday - active
1 : Sunday - active
```

Profile current light dim level in HEX

32

Profile current light dim level converted to decimal

50%

fPort 25 Usage Message*

| Byte 0 | Byte 1 | Byte .. | Byte n |
|--------------------|-----------------|---------|--------|
| Addr | Reported fields | Payload | |
| uint_8 0..255** | | | |

| Bit # | Parameter | Type and unit |
|-------|--------------------------|---------------|
| 0 | Active energy total | uint32, Wh |
| 1 | Active energy instant | uint16, W |
| 2 | Load side energy total | uint32, Wh |
| 3 | Load side energy instant | uint16, W |
| 4 | Power factor instant | uint8 *** |
| 5 | System voltage | uint8, V |
| 6 | RFU | |
| 7 | RFU | |

* If driver supports. Also drivers need to have short addresses assigned.

** 0xFF values measured by the controller. If driver value is available, it is preferred over internal measurement.

*** Needs to be divided by 100.

Usage parameters are reported after driver address in order of the reported fields mapping. If more than one driver are connected, then next drivers address is reported after the last parameter of the first driver and followed by the parameters in the same logic.

Message sample

Message in base64

```
BAMAAAAAAAAAGA xUUAAAAA==
```

Message decoded to HEX

```
04030000000000000603151400000000
```

Address 1

DALI address in HEX

```
04
```

Profile HEX address converted to DALI address

```
Single address 2
```

Reported fields in HEX

```
03
```

Reported fields converted to binary

```
00000011
```

Binary converted to statuses (LSB)

```
1 : Active energy total - sent
1 : Active energy instant - sent
0 : Load side energy total - not sent
0 : Load side energy instant - not sent
0 : Power factor instant - not sent
0 : System voltage - not sent
0 : RFU
0 : RFU
```

Active energy total 00000000 HEX message flip for MSB

```
00000000
```

HEX message converted to decimal

```
0 (Wh)
```

Current consumption 0000 HEX message flip for MSB

```
0000
```

HEX message converted to decimal

```
0 (W)
```

Address 2

DALI address in HEX

```
06
```

Profile HEX address converted to DALI address

```
Single address 3
```

Reported fields in HEX

03

Reported fields converted to binary

00000011

Binary converted to statuses (LSB)

```
1 : Active energy total - sent
1 : Active energy instant - sent
0 : Load side energy total - not sent
0 : Load side energy instant - not sent
0 : Power factor instant - not sent
0 : System voltage - not sent
0 : RFU
0 : RFU
```

Active energy total 15140000 HEX message flip for MSB

00001415

HEX message converted to decimal

5141 (Wh)

Current consumption 0000 HEX message flip for MSB

0000

HEX message converted to decimal

0 (W)

fPort 50 Configuration Message

| Byte0 | Byte ... | Byte n |
|--------|----------|--------|
| Header | Payload | |

Different headers with their respective payloads are described below

Sunrise/Sunset offset configuration*

| Byte 0 | Byte 1 | Byte 2 | Byte 3 | Byte 4 | Byte 5 | Byte 6 |
|--------|----------------------|---------------------|----------|--------|-----------|--------|
| Header | Sunrise offset - min | Sunset offset - min | Latitude | | Longitude | |
| 06 | int_8 | int_8 | int_16** | | int_16** | |

*0x06FFFFFFFFFFFFFF will disable the sunrise/sunset calendar

**2 decimals times 100. Example : 59.425284 > 59.43 > 5943

Message sample

Message goal: Set lights to turn off 30 minutes before sunrise and turn on 30 minutes after sunrise. Set calendar to Viimsi, Estonia.

Header

Select Header HEX code

06

Sunrise offset

Convert offset -30 to HEX

E2

Sunset offset

Convert offset 30 to HEX

1E

Latitude

Convert coordinates 65.500226 to 2 decimals

65.50

Multiply with 100 to get rid of the decimal places

6550

Convert to HEX

1996

Flip HEX value to LSB

9619

Longitude

Convert coordinates `24.833547` to 2 decimals

```
24.83
```

Multiply with 100 to get rid of the decimal places

```
2483
```

Convert to HEX

```
9B3
```

Flip HEX value to LSB

```
B309
```

Compile message for sending (HEX)

```
06E21E9619B309
```

Control value in base64 to control after sending

```
BuIelhmzCQ==
```

Status reporting configuration

| Byte 0 | Byte 1 | Byte 2 | Byte 3 | Byte 4 |
|--------|----------------------|--------|--------|--------|
| Header | Status interval* - s | | | |
| 07 | uint_32 | | | |

* Minimum value - 600

Message sample

Message goal: Set status reporting to 1 hour

Header

Select Header HEX code

07

Reporting interval

Convert interval 3600 to HEX

E10

Flip HEX value to LSB

100E0000

Compile message for sending (HEX)

07100E0000

Control value in base64 to control after sending

BxAOAAA=

Profile configuration

| Byte 0 | Byte 1 | Byte 2 | Byte 3 | Byte 4 | Byte 5 | Byte 6 | Byte * | Byte * | Byte 35 | Byte 36 |
|--------|------------|--------------|--------|--------|----------------|--------------|-----------------|--------------|-----------------|--------------|
| Header | Profile ID | Profile seq. | Addr. | Day | Dimming step 1 | | Dimming step .. | | Dimming step 10 | |
| 08 | 0..254 | 0..254 | 0..255 | | Step time* | Dimming val. | Step time* | Dimming val. | Step time* | Dimming val. |
| | | | | | 0..143 | 0..100 | 0..143 | 0..100 | 0..143 | 0..100 |

| Value | Bit # | Parameter |
|--------------------------------|-------|-----------|
| 0: not selected 1: Selected | 0 | Holidays |
| | 1 | Monday |
| | 2 | Tuesday |
| | 3 | Wednesday |
| | 4 | Thursday |
| | 5 | Friday |
| | 6 | Saturday |
| | 7 | Sunday |

* Step time is 10 min increment from 00:00:00. Look at the profile step time chart for more details.

Message sample

Message goal: Apply profile 22 sequence 3 to Broadcast address to dim the lights (01:00 to 30%, 06:00 to 80%, 10:00 to 30%, 17:00 to 80%) on Mondays, Tuesdays, Wednesdays and Thursdays.

Header

Select Header HEX code

08

Profile ID

Convert profile ID 22 to HEX

16

Sequence

Convert profile sequence 3 to HEX

03

Address

Convert Broadcast address to HEX

FE

Day

Day selection

```
0 : Holidays - not active
1 : Monday - active
1 : Tuesday - active
1 : Wednesday - active
1 : Thursday - active
0 : Friday - not active
0 : Saturday - not active
0 : Sunday - not active
```

Selection converted to binary

```
00011110
```

Selection converted to HEX

```
1E
```

Dimming step 1

Choose desired time

```
01:00
```

Convert time to offset

```
6 (see step time conversion map)
```

Convert offset to HEX

```
06
```

Choose desired dimming level

```
30%
```

Convert level to HEX

```
1E
```

Dimming step 2

Choose desired time

```
06:00
```

Convert time to offset

```
36 (see step time conversion map)
```

Convert offset to HEX

```
24
```

Choose desired dimming level

```
80%
```

Convert level to HEX

```
50
```

Dimming step 3

Choose desired time

10:00

Convert time to offset

60 (see step time conversion map)

Convert offset to HEX

3C

Choose desired dimming level

30%

Convert level to HEX

1E

Dimming step 4

Choose desired time

17:00

Convert time to offset

102 (see step time conversion map)

Convert offset to HEX

66

Choose desired dimming level

80%

Convert level to HEX

50

Compile message for sending (HEX)

081603FE1E061E24503C1E6650

Control value in base64 to control after sending

CBYD/h4GHirQPb5mUA==

Time settings

| Byte 0 | Byte 1 | Byte 2 | Byte 3 | Byte 4 |
|--------|--------------------------------------|--------|--------|--------|
| Header | Device clock (Unix timestamp in UTC) | | | |
| 09 | uint32 | | | |

Message sample

Message goal: Set device clock to 22 August 2017 11:50:00

Header

Select Header HEX code

09

Device clock

Choose desired time

22 August 2017 11:50:00 (UTC)

Convert to epoch

1503402600

Covert to hex

599C1A68

Flip HEX value for LSB

681A9C59

Compile message for sending (HEX)

09681A9C59

Control value in base64 to control after sending

CWganFk=

Default settings

| Byte 0 | | Byte 1 | | Byte 2 | | |
|--------|--|----------------------|--|--------------|--|--|
| Header | | Default light 0..100 | | Alert enable | | |
| OA | | uint8 | | | | |

| Bit # | Function | Value |
|-------|-------------------|---------------------------|
| 0 | LDR alarm enable | 0: off (default) 1: on |
| 1 | THR alarm enable | |
| 2 | DIG alarm enable | |
| 3 | DALI alarm enable | |
| 4 | RFU | |
| 5 | RFU | |
| 6 | RFU | |
| 7 | RFU | |

Message sample

Message goal: Set default light to 0% and enable DALI alerts

Header

Select Header HEX code

0A

Default light

Convert default light dim level 0% from decimal to HEX

00

Alerts

Alert selection

```
0 : LDR alarm - disable
0 : THR alarm - disable
0 : DIG alarm - disable
1 : DALI alarm - enable
0 : RFU
0 : RFU
0 : RFU
0 : RFU
```

Selection converted to binary

00001000

Selection converted to HEX

08

Compile message for sending (HEX)

0A0008

Control value in base64 to control after sending

CgAI

Usage reporting configuration

| Byte 0 | Byte 1 | Byte 2 | Byte 3 | Byte 4 | Byte 5 |
|--------|---------------------|--------|--------|------------------|--------|
| Header | Usage interval* - s | | | System voltage** | |
| 0B | uint_32 | | | uint_8 | |

* Minimum value - 600

** Default 230

Message sample

Message goal: Set usage reporting to 1 hour and system voltage to 240V.

Header

Select Header HEX code

0B

Reporting interval

Convert interval 3600 to HEX

E10

Flip HEX value to LSB

100E0000

System voltage

Convert voltage 240 to HEX

F0

Compile message for sending (HEX)

0B100E0000F0

Control value in base64 to control after sending

CxAOAADw

Holiday configuration

| Byte 0 | Byte 1 | Byte 2 | Byte .. | Byte .. | Byte 49 | byte 50 |
|--------|-----------|--------|------------|---------|------------|---------|
| Header | Holiday 1 | | Holiday .. | | Holiday 25 | |
| 0C | 0..355 | | 0..355 | | 0..355 | |

Holiday are marked with days from January 1. Maximum of 25 holidays is supported. Sending in configuration for new holidays will replace old config

Message sample

Message goal: Configure January 1st, Febraury 24th, May 1st, June 23rd, August 20th and December 23rd as holidays.

Header

Select Header HEX code

0C

Holiday 1

Choose desired day

January 1st

Convert to day number in year

1

Convert value to HEX

01

Flip HEX value for LSB

0100

Holiday 2

Choose desired day

February 24th

Convert to day number in year

55

Convert value to HEX

37

Flip HEX value for LSB

3700

Holiday 3

Choose desired day

May 1st

Convert to day number in year

121

Convert value to HEX

79

Flip HEX value for LSB

7900

Holiday 4

Choose desired day

June 23rd

Convert to day number in year

174

Convert value to HEX

AE

Flip HEX value for LSB

AE00

Holiday 5

Choose desired day

August 20th

Convert to day number in year

234

Convert value to HEX

E2

Flip HEX value for LSB

E200

Holiday 6

Choose desired day

December 23rd

Convert to day number in year

357

Convert value to HEX

165

Flip HEX value for LSB

6501

Compile message for sending (HEX)

0c010037007900AE00E2006501

Control value in base64 to control after sending

DAEANwB5AK4A4gB1AQ==

Clear Configuration

| Byte 0 | Byte 1 | Byte 2 | Comment |
|--------|----------|-----------------|--------------------------|
| Header | Function | | |
| FF | 01 | N/A | Clear LDR settings |
| | 02 | N/A | Clear THR settings |
| | 03 | N/A | Clear DIG settings |
| | 04 | Addr. 0..255 | Clear profile from addr. |
| | 05 | N/A | RFU |

Message sample

Message goal: Clear configuration from DALI broadcast address

Header

Select Header HEX code

FF

Function

Select clear profile function

04

Destination address

Convert DALI Broadcast address to HEX

FE

Compile message for sending (HEX)

FF04FE

Control value in base64 to control after sending

/wT+

fPort 51 OTA Activation Message

| Byte 0 | Comment |
|--------|-----------------------------|
| Header | |
| FF | Activates OTA for 2 minutes |

Message sample

Message goal: Enable OTA mode

Header

Select Header HEX code

FF

Compile message for sending (HEX)

FF

Control value in base64 to control after sending

/w==

fPort 52 Configure Multicast*

* The Multicast key provisioning is not yet according to LoRa Alliances "LoRaWAN® Remote Multicast Setup Specification v1.0.0"

Set Multicast

| Byte 0 | Byte 1..Byte 4 | Byte 5..Byte 20 | Byte 21..Byte 36 |
|---------------------------------------|----------------|-----------------|------------------|
| Header | DevAddr | NwkSKey | AppSKey |
| 0x01..0x03 Multicast group number* | HEX | HEX | HEX |

* Upto 3 different sets of Multicast keys can be configured. When the same set number is used, then the old keys are overwritten.

Message sample

Message goal: Set Multicast group 1 keys to DevAddr: 82840c70,
NwkSKey: 82840c7056429b143d21974557f93a53, AppSKey: 82840c70c08494b931fe2fa6f8835c6a

Header

Select Header HEX code

```
0x01
```

DevAddr

DevAddr in HEX

```
82840c70
```

NwkSKey

NwkSKey in HEX

```
82840C7056429B143D21974557F93A53
```

AppSKey

AppSKey in HEX

```
82840C70C08494B931FE2FA6F8835C6A
```

Compile message for sending (HEX)

```
01|82840c70|082840c7056429b143d21974557f93a53|82840c70c08494b931fe2f  
a6f8835c6a
```

Control value in base64 to control after sending

```
AYKEDHCChAxwVkJbFD0h10VX+TpTgoQMCElLkx/i+m+INcag==
```

Clear Multicast Configuration

| Byte 0 | Byte 1 |
|--------|--|
| Header | Multicast group |
| 0xFF | 0x01..0x03 Clear group number 0xFF - Clear all groups |

Message sample

Message goal: Clear Multicast group number 2

Header

Select Header HEX code

0xFF

Group number

Group number in HEX

0x02

Compile message for sending (HEX)

FF02

Control value in base64 to control after sending

/wI=

fPort 60 Command Message

| Byte0 | Byte ... | Byte n |
|--------|----------|--------|
| Header | Payload | |

Different headers with their respective payloads are described below

Query detailed DALI status

| Byte 0 | Byte 1 |
|--------|---------|
| Header | Address |
| 00 | 0..254* |

* Value 254(0xFE) Queries all the automatically detected ballasts and sends the statuses as an array (Maximum of 25 items).

Message sample

Message goal: Get status of all connected DALI devices

Header

Select Header HEX code

00

Destination address

Convert DALI Broadcast address to HEX

FE

Compile message for sending (HEX)

00FE

Control value in base64 to control after sending

AP4=

Answer for detailed DALI status query (uplink only)

| Byte 0 | Byte 1 | Byte 2 | Byte * | Byte * | Byte 49 | Byte 50 |
|--------|------------------------|--------|-----------|--------|-------------------------|---------|
| Header | 1 st device | | .. device | | 25 th device | |
| | Addr. | Status | Addr. | Status | Addr. | Status |
| 00 | 0..255 | 0..255 | 0..255 | 0..255 | 0..255 | 0..255 |

Message sample

Message in base64

```
AAIEBgIMAg==
```

Message decoded to hex

```
00020406020c02
```

Header 00 decoded

```
Answer for detailed DALI status request
```

1st Device status

Profile address in HEX

```
02
```

Profile HEX address converted to DALI address

```
Single device 1
```

DALI status in HEX

```
04
```

HEX value converted to status

```
Ballast is off
```

2nd Device status

Profile address in HEX

```
06
```

Profile HEX address converted to DALI address

```
Single device 3
```

DALI status in HEX

```
02
```

HEX value converted to status

```
Lamp is burned out
```

3rd Device status

Profile address in HEX

0C

Profile HEX address converted to DALI address

Single device 6

DALI status in HEX

02

HEX value converted to status

Lamp is burned out

Set Dimming level

| Byte 0 | Byte 1 | Byte 2 | Byte * | Byte * | Byte 9 | Byte 10 |
|--------|--------|-----------|--------|-----------|--------|-----------|
| Header | Addr. | Dim level | Addr. | Dim level | Addr. | Dim level |
| 01 | 0..255 | 0..100 | 0..255 | 0..100 | 0..255 | 0..100 |

Message sample

Message goal: Set all luminaires to 100%

Header

Select Header HEX code

01

Destination address

Convert DALI Broadcast address to HEX

FE

Dimming level

Convert light dimming level 100% from decimal to HEX

64

Compile message for sending (HEX)

01FE64

Control value in base64 to control after sending

Af5k

Custom DALI request

| Byte 0 | Byte 1 | Byte 2 | Byte * | Byte * | Byte 9 | Byte 10 |
|--------|--------|--------|--------|--------|--------|---------|
| Header | Addr. | Query | Addr. | Query | Addr. | Query |
| 03 | 0..255 | 0..255 | 0..255 | 0..255 | 0..255 | 0..255 |

Message sample

Message goal: Ask Max level, Min Level, Power on level, System failure level and Fade time/rate from device 36

Header

Select Header HEX code

03

1st Query

Destination address

Convert DALI Single device 36 address to HEX

48

Convert Max level query code 161 to HEX

A1

2nd Query

Destination address

Convert DALI Single device 36 address to HEX

48

Convert Min level query code 162 to HEX

A2

3rd Query

Destination address

Convert DALI Single device 36 address to HEX

48

Convert Power on level query code 163 to HEX

A3

4th Query

Destination address

Convert DALI Single device 36 address to HEX

48

Convert System failure level query code 164 to HEX

A4

5th Query

Destination address

Convert DALI Single device 36 address to HEX

48

Convert Fade time/rate query code 165 to HEX

A5

Compile message for sending (HEX)

0348A148A248A348A448A5

Control value in base64 to control after sending

A0ihSKJIo0ikSKU=

Answer for custom DALI request

| Byte 0 | Byte 1 | Byte 2 | Byte 3 | Byte * | Byte * | Byte * | Byte 47 | Byte 48 | Byte 49 |
|--------|--------|--------|--------|--------|--------|--------|---------|---------|---------|
| Header | Addr. | Query | Answer | Addr. | Query | Answer | Addr. | Query | Answer |
| 03 | 0..255 | 0..255 | 0..255 | 0..255 | 0..255 | 0..255 | 0..255 | 0..255 | 0..255 |

Message sample

Message in base64

BEih/kiiqEij/kik/kilBw==

Message decoded to hex

0448A1FE48A2A848A3FE48A4FE48A507

Header 04 decoded

Answer for custom DALI request

1st Answer

Profile address in HEX

48

Profile HEX address converted to DALI address

Single device 36

Query in HEX

A1

HEX value converted to decimal

161

Decimal value translated to query

Max level

Answer in HEX

FE

HEX value converted to decimal

254

2nd Answer

Profile address in HEX

48

Profile HEX address converted to DALI address

Single device 36

Query in HEX

A2

HEX value converted to decimal

162

Decimal value translated to query

Min level

Answer in HEX

A8

HEX value converted to decimal

168

3rd Answer

Profile address in HEX

48

Profile HEX address converted to DALI address

Single device 36

Query in HEX

A3

HEX value converted to decimal

163

Decimal value translated to query

Power on level

Answer in HEX

FE

HEX value converted to decimal

254

4th Answer

Profile address in HEX

48

Profile HEX address converted to DALI address

Single device 36

Query in HEX

A4

HEX value converted to decimal

164

Decimal value translated to query

Failure level

Answer in HEX

FE

HEX value converted to decimal

254

5th Answer

Profile address in HEX

48

Profile HEX address converted to DALI address

Single device 36

Query in HEX

A5

HEX value converted to decimal

165

Decimal value translated to query

Fade time/rate

Answer in HEX

07

HEX value converted to status

<0.7s / 45 steps/s

Custom DALI command

| Byte 0 | Byte 1 | Byte .. | Byte 50 |
|--------|--------|---------|---------|
| Header | Data | Data | Data |
| 04 | 0..255 | 0..255 | 0..255 |

Message sample

Message goal: Set Single device 1 minimum light level to 127.

Header

Select Header HEX code

04

DALI command

DALI command in HEX

027F0321032B

Compile message for sending (HEX)

04027F0321032B

Control value in base64 to control after sending

BAJ/AyEDKw==

fPort 99 Boot/Debug Message

| Byte 1 | Byte 2 | Byte 3 | Byte 4 | Byte 5 | Byte 6 | Byte 7 | Byte 8 | Byte 9 | Byte 10 | Byte 11 | Byte 12 | Byte 12 | Byte 12 |
|-----------------|-------------------|--------|--------|----------------|--------|--------|-----------------------------------|--------|---------|----------|------------|---------|---------|
| Header (HEX) | Payload | | | | | | | | | | | | |
| 0x00 Boot | Serial (HEX) | | | Firmware (HEX) | | | Clock - Unix timestamp UTC (uint) | | | HW (HEX) | Opt. (HEX) | | |
| 0x01 Shutdown | | | | | | | | | | | | | |
| 0x10 Error code | Error code (uint) | | | | | | | | | | | | |

Error codes

| Code | Comment |
|------|--|
| 02 | Multiple unconfigured drivers detected |

Message sample

Message in base64

```
AP8AEEcABAXDFEFZBQA=
```

Message decoded to hex

```
00FF001047000405C31441590500
```

Header 00 decoded

```
Boot message
```

Device serial FF001047 HEX message flip for MSB

```
471000FF
```

Firmware version

Major version in HEX

```
00
```

HEX value converted to decimal

```
0
```

Minor version in HEX

```
04
```

HEX value converted to decimal

```
4
```

Patch version in HEX

```
05
```

HEX value converted to decimal

```
5
```

Device clock C3144159 HEX message flip for MSB

```
594114C3
```

HEX message converted to decimal (epoch)

```
1497437379 (seconds)
```

Epoch time converted to date

```
14 June 2017 10:49:39 (UTC)
```

Hardware configuration

Hardware setup in HEX

```
05
```

HEX value converted to setup

```
DALI & 0..10V & NC Realy
```

Optional features in HEX

```
00
```

HEX value converted to optional features

```
None
```

Cells marked with X contain address bits

DALI Address / Destination mapping

| Bit # | Single address | Group address | Broadcast |
|-------|----------------|---------------|-----------|
| Addr. | 0-63 | 0-15 | n/a |
| 0 | 0 | 0 | 0 |
| 1 | x | x | 1 |
| 2 | x | x | 1 |
| 3 | x | x | 1 |
| 4 | x | x | 1 |
| 5 | x | 0 | 1 |
| 6 | x | 0 | 1 |
| 7 | 0 | 1 | 1 |

PROFILE STEP TIME CHART

| | | | | |
|------------|------------|------------|-------------|-------------|
| 0 - 00:00 | 29 - 04:50 | 58 - 09:40 | 87 - 14:30 | 116 - 19:20 |
| 1 - 00:10 | 30 - 05:00 | 59 - 09:50 | 88 - 14:40 | 117 - 19:30 |
| 2 - 00:20 | 31 - 05:10 | 60 - 10:00 | 89 - 14:50 | 118 - 19:40 |
| 3 - 00:30 | 32 - 05:20 | 61 - 10:10 | 90 - 15:00 | 119 - 19:50 |
| 4 - 00:40 | 33 - 05:30 | 62 - 10:20 | 91 - 15:10 | 120 - 20:00 |
| 5 - 00:50 | 34 - 05:40 | 63 - 10:30 | 92 - 15:20 | 121 - 20:10 |
| 6 - 01:00 | 35 - 05:50 | 64 - 10:40 | 93 - 15:30 | 122 - 20:20 |
| 7 - 01:10 | 36 - 06:00 | 65 - 10:50 | 94 - 15:40 | 123 - 20:30 |
| 8 - 01:20 | 37 - 06:10 | 66 - 11:00 | 95 - 15:50 | 124 - 20:40 |
| 9 - 01:30 | 38 - 06:20 | 67 - 11:10 | 96 - 16:00 | 125 - 20:50 |
| 10 - 01:40 | 39 - 06:30 | 68 - 11:20 | 97 - 16:10 | 126 - 21:00 |
| 11 - 01:50 | 40 - 06:40 | 69 - 11:30 | 98 - 16:20 | 127 - 21:10 |
| 12 - 02:00 | 41 - 06:50 | 70 - 11:40 | 99 - 16:30 | 128 - 21:20 |
| 13 - 02:10 | 42 - 07:00 | 71 - 11:50 | 100 - 16:40 | 129 - 21:30 |
| 14 - 02:20 | 43 - 07:10 | 72 - 12:00 | 101 - 16:50 | 130 - 21:40 |
| 15 - 02:30 | 44 - 07:20 | 73 - 12:10 | 102 - 17:00 | 131 - 21:50 |
| 16 - 02:40 | 45 - 07:30 | 74 - 12:20 | 103 - 17:10 | 132 - 22:00 |
| 17 - 02:50 | 46 - 07:40 | 75 - 12:30 | 104 - 17:20 | 133 - 22:10 |
| 18 - 03:00 | 47 - 07:50 | 76 - 12:40 | 105 - 17:30 | 134 - 22:20 |
| 19 - 03:10 | 48 - 08:00 | 77 - 12:50 | 106 - 17:40 | 135 - 22:30 |
| 20 - 03:20 | 49 - 08:10 | 78 - 13:00 | 107 - 17:50 | 136 - 22:40 |
| 21 - 03:30 | 50 - 08:20 | 79 - 13:10 | 108 - 18:00 | 137 - 22:50 |
| 22 - 03:40 | 51 - 08:30 | 80 - 13:20 | 109 - 18:10 | 138 - 23:00 |
| 23 - 03:50 | 52 - 08:40 | 81 - 13:30 | 110 - 18:20 | 139 - 23:10 |
| 24 - 04:00 | 53 - 08:50 | 82 - 13:40 | 111 - 18:30 | 140 - 23:20 |
| 25 - 04:10 | 54 - 09:00 | 83 - 13:50 | 112 - 18:40 | 141 - 23:30 |
| 26 - 04:20 | 55 - 09:10 | 84 - 14:00 | 113 - 18:50 | 142 - 23:40 |
| 27 - 04:30 | 56 - 09:20 | 85 - 14:10 | 114 - 19:00 | 143 - 23:50 |
| 28 - 04:40 | 57 - 09:30 | 86 - 14:20 | 115 - 19:10 | |

PINOUT

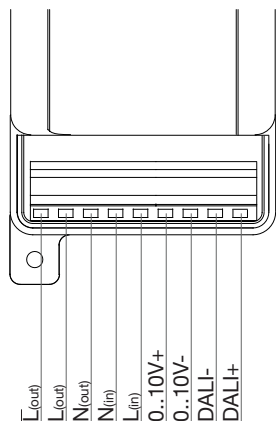

Pinout is also marked on the controller

| Connector | Description |
|---------------------------|------------------------------------|
| Power Connections: | |
| $L_{(in)}$ | 230V AC line input |
| N | 230V AC neutral input/output |
| $L_{(out)}$ | AC 230V output |
| $\bar{L}_{(out)}$ | Inverted AC 230V output |
| Control outputs: | |
| DALI+/DALI- | DALI control to driver |
| 0..10V | Analog control 0(1)..10V to driver |

ORDERING INFORMATION

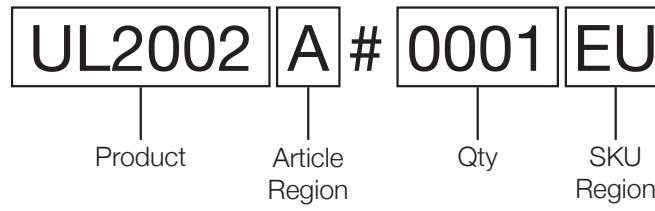

| Product/SKU | Package qty | IP Rating |
|----------------|-------------|-----------|
| UL2002x#0001xx | 1 | IP54 |

| Article region | SKU region | Frequency |
|----------------|------------|-----------|
| A | EU | 868 MHz |
| B | AU | 922 MHz |
| C | US | 915 MHz |
| D | AS | 923 MHz |
| F | KR | 922 MHz |
| I | IN | 866 MHz |

CONTACT INFORMATION

Nordic Automation Systems AS

www.nasys.no

info@nasys.no

REVISION HISTORY

- 1.0 - First version
- 1.1 - Added configuration details.
- 1.2 - Added configuration details.
- 1.3 - Updated communication protocol
- 1.4 - Wiring diagram and ordering information
- 1.5 - fw 0.5.0 support, power metering
- 2.0 - Split from UL2011 datasheet
- 2.1 - Updated to UL2002
- 2.2 - New format for usage message. Calendar user configurable
- 2.3 - Added Multicast configuration

All content contained herein is subject to change without notice. Nordic Automation Systems reserves the right to change or modify the content at any time.